

Technical Design Curriculum

An Approach

- A. Introduction to Design
 - Drawing Standards
 - Design Process
 - Sample Student Handouts

- B. Grade 10 Projects
 - i. Remote Controller
 - ii. Athletic Footwear

- C. Grade 11 Project
 - i. Solar Car
 - ii. Eyewear

- D. Grade 12 Project
 - i. Computer Speaker
 - ii. Chess Set

Introduction to Design

What is Design

Design is the thought process comprising the creation of an entity.

“Design is the process for making things right for shaping what people need.”

Ralph Caplan

“We feel that good design must primarily serve people, and not the other way around.”

Thomas J Watson, IBM

Purpose of Design

The solution was a necessity.

The solution would improve the quality of life

Areas of Design/Design Fields

To list a few...

- Architectural Design
- Graphic Design
- Product/Industrial Design
- Automotive Design
- Engineering Design
- Landscape Design

This curriculum will focus on *product/industrial design* in combination with AliasStudio 2009.

Drawing Standards

Orthographic Projection

Orthographic projection is a means of representing a three-dimensional (3D) object in two dimensions (2D). It uses multiple views of the object from points of view rotated about the object's center through increments of 90° . Equivalently, the views may be considered to be obtained by rotating the object about its center through increments of 90° .

Orthographic views describe an object completely.

3 Orthographic Views of a Concept Car



Front View



Side View



Back View

Dimensioning

Working Drawing

A working drawing is one from which a tradesperson can manufacture a part. The drawing must be a complete set of instructions, so that it will not be necessary to give further information to the person(s) fabricating the part. A working drawing consists of all the necessary views, dimensions and any required specifications, such as type of material. The required specifications can be found as notes on the drawing or it located in the title block.

Dimensioning Rules and Common Practices

- The same dimension is not required on multi-view drawings.

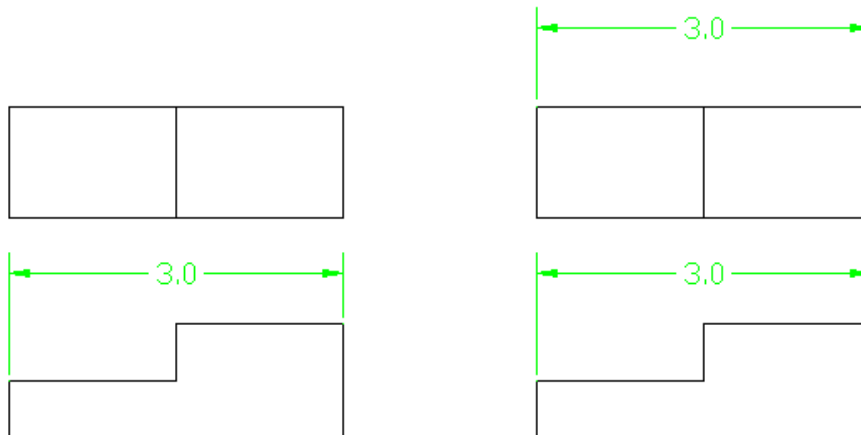

Correct

Incorrect

- Overall dimensions are placed outside the smaller dimensions.

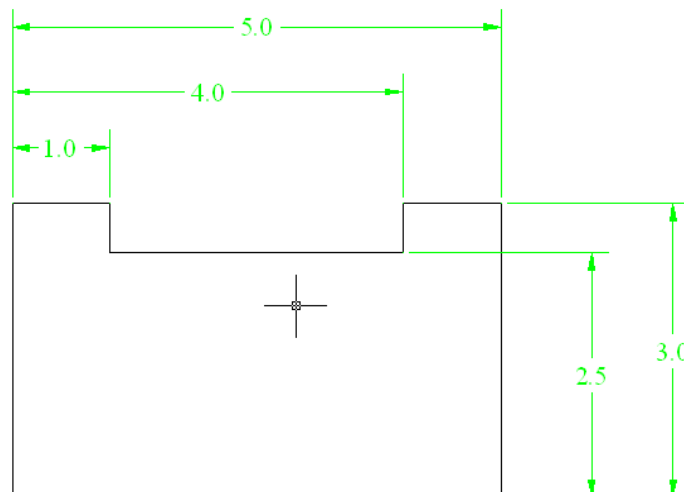

- Dimensions are given from centerlines where necessary.

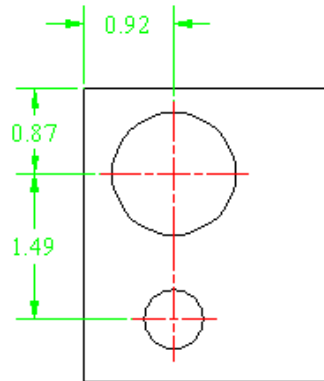

- Always give the diameter of a hole, not the radius.

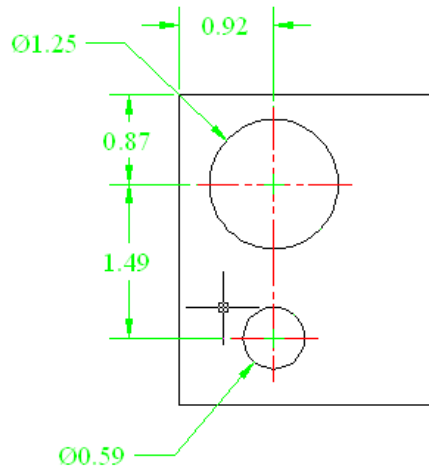

- Always give the radius of an arc using a leader. An “R” should be placed before the value.

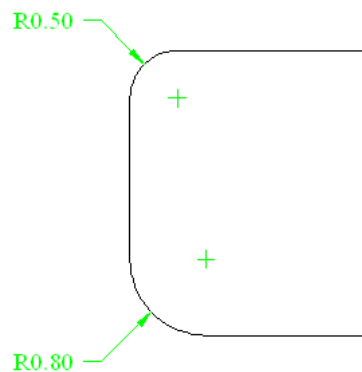

- Dimensions are generally not placed inside the view outlines.

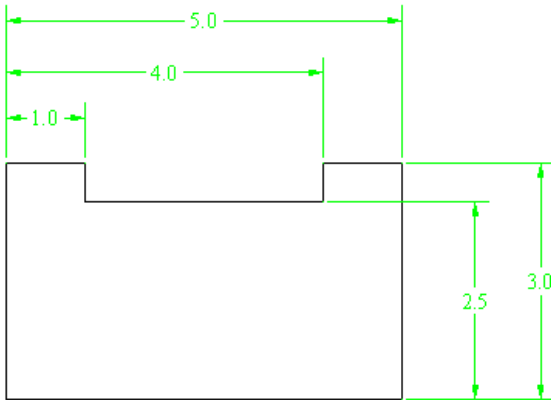

Correct

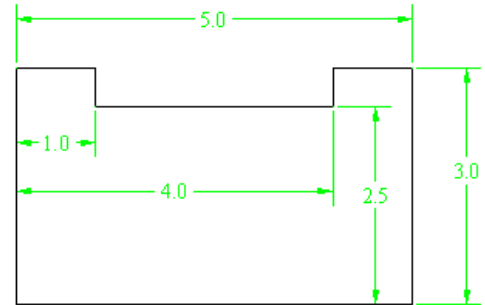

Incorrect

- Extension lines are placed so they do not cross dimension lines.

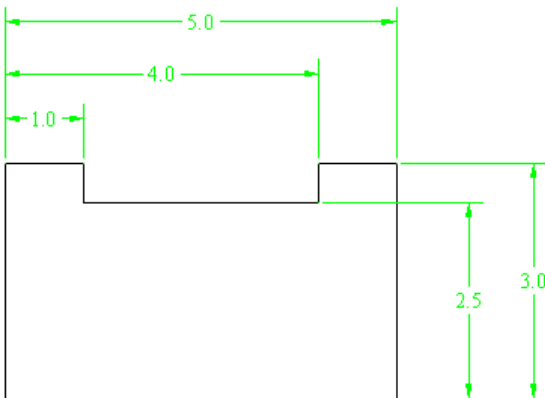

Correct

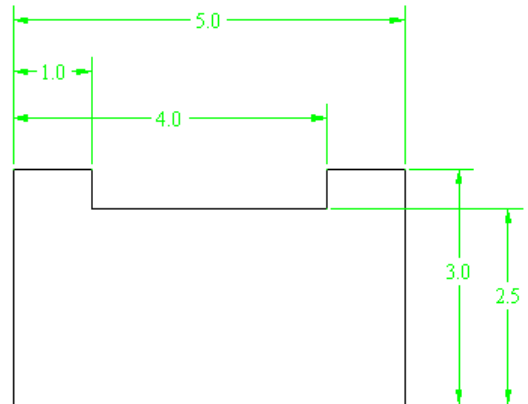

Incorrect

- Avoid dimensioning to hidden lines.

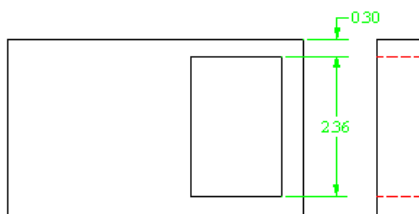

Correct

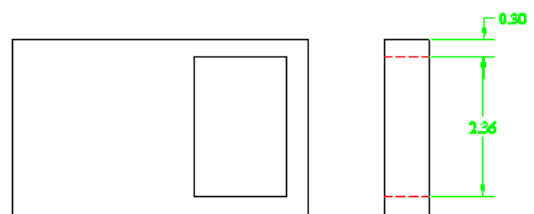

Incorrect

- Place dimensions near the views, between views and above the views when ever possible.

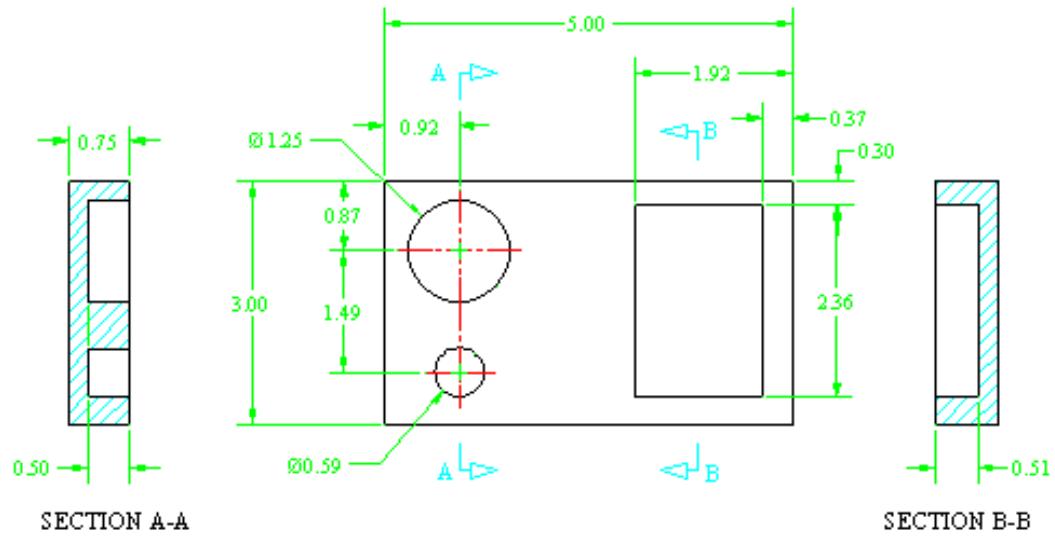

Design Process

Design is a progressive process that follows a general course of 4 stages.

- **Research** research and analysis of what's
- **Concept** a search for ideas which solve problems
- **Development** a search for formal characteristics
- **Formalization** working drawings, models and prototypes

Thinking during the Design Process

The stages in the design development are characterized by the following kinds of thinking.

- **Marketing** this requires knowledge of the company, the competitors, the marketplace, the customers and the price.
- **Human Factors** the study of people sizes and how they relate to the design
- **Manufacturing** will it be mass produced and from which materials and manufacturing process
- **Form Giving** aesthetics

Design Process – Research

There are endless sources of information for use in any design project.

History of the Product

Studying the past evolution of the designs of similar products can help identify trends for new development. Studying old designs will also help understand the designers who have preceded you. Understanding how they worked can also help young designer find new (old) ideas which have been forgotten or neglected.

Marketplace and Competitors

Understanding the marketplace and competitors is fundamental to the success of any new product design. Also, understanding who the target consumer is and what motivates them to buying something is the basis of all successful business.

Materials and Manufacturing

Often introducing a new material, process or assembly procedure can mean the difference between success or failure.

The following important questions must be answered:

What materials the products are made of?

How are the parts and components made?

How are the products assembled?

Why are these practices used in industry now?

Why are other materials, processes and assembly sequences not used?

Resources

Websites

www.pltw.org	Project Lead the Way – Engineering
www.asme.org	American Society of Mechanical Engineers
www.core77.com	Industrial Design
www.idsa.com	Industrial Designers Society of America
www.cardesign.com	Automotive Design
conceptcar.co.uk	Automotive Design

Magazines

ID	Industrial Design
Auto and Design	Automotive Design
Cadalyst	CAD News
Newdesign	Products and Processes of Design

Texts

- Drafting: Technology and Practice
William P. Spence
Glencoe/McGraw Hill
- Product Design and Development
Karl T. Ulrich Steven D. Eppinger
Irwin McGraw-Hill
- Introduction to Engineering
Juliet Morris
McGraw-Hill

Reference Books

- Design: An Illustrated Historical Overview
Thomas Hauffe
Barron's
- Henry Dreyfuss: Industrial Designer
Russell Flinchum
Rizzoli International
- Design Sketching
Erik Olofsson Klara Sjölen
KEEOS Design Books
- The Look of the Century
Michael Tambini
DK Publishing
- Presentation Techniques
Dick Powell
Little, Brown
- Dictionary of 20th Century Design
John Pile
Roundtable Press
- Design – A Very Short Introduction
John Heskett
Oxford

Design Process - Concept

In the design process the student must explore alternative designs.

Concept Sketches

- Concept sketches should have a minimum of 10 –1 5 ideas.
- Should be completed in pencil or marker.
- Colour the sketch that has been chosen for your final design.
Try to colour the sketch as the actual materials ie. Plastic/metal
Use markers or pencil crayons.
- Concept Sketches are not drawn freehand and not to scale.
- Include any notes of functions or features not evident by the sketch.

Scaled Sketches

- All Scaled Sketches are to be completed on graph paper.
- Each scaled sketch will be drawn a scale determined by the product to be designed.
- Produced the views necessary to describe the product completely.
- Scale, set square, circle/ellipse template, French curve and compass should be used to produce an accurate and neat set of scaled sketches.
- The sketches will also include all dimensions
- Scaled Sketches are produced in pencil only.

Design Process - Development

Size and Shape Finalized – Dimensions

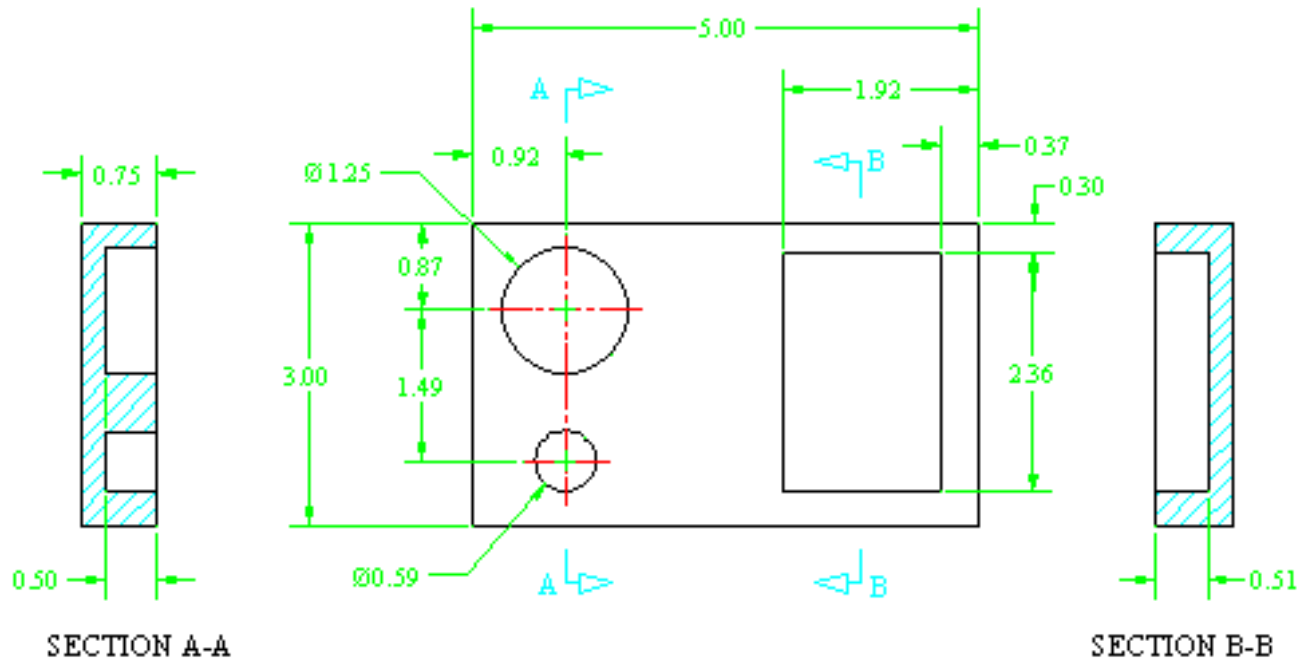

Formal CAD Drawings

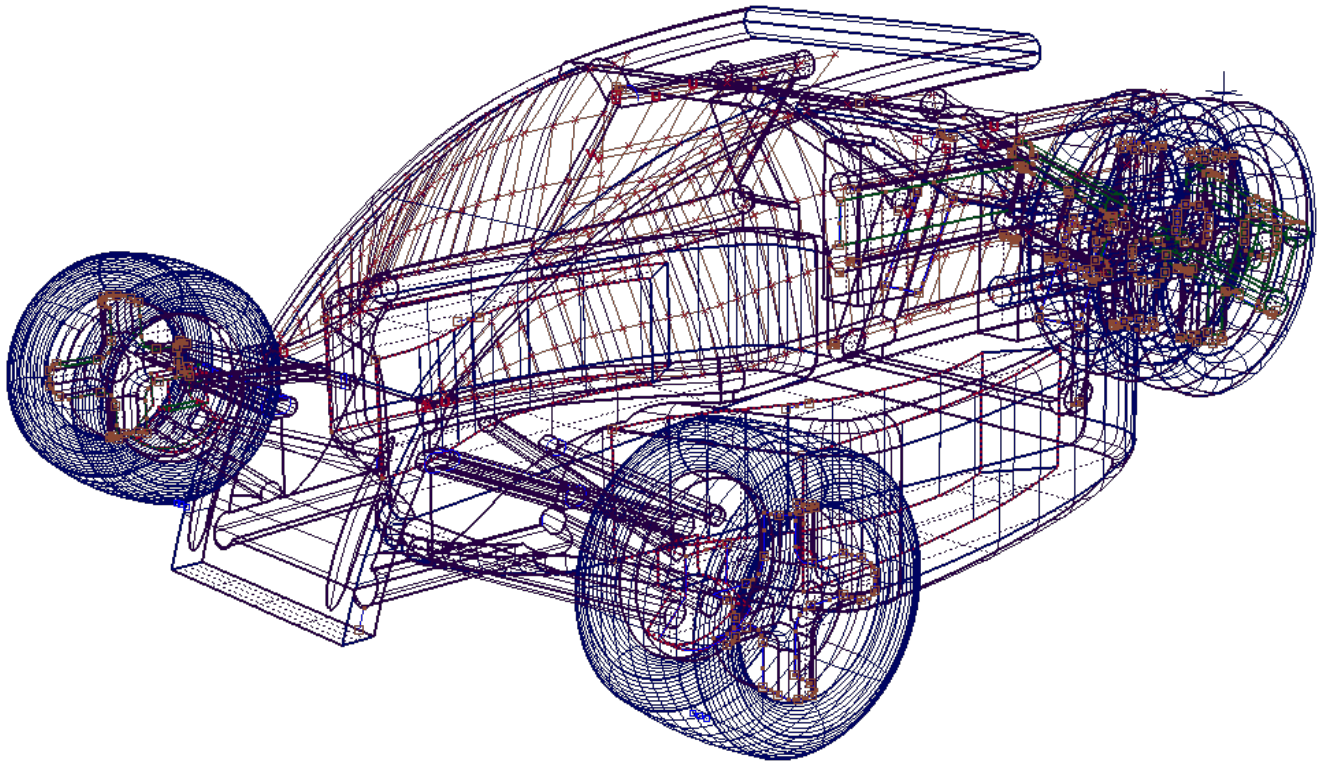

3D Concept Car Model created using AliasStudio

CAD Rendering

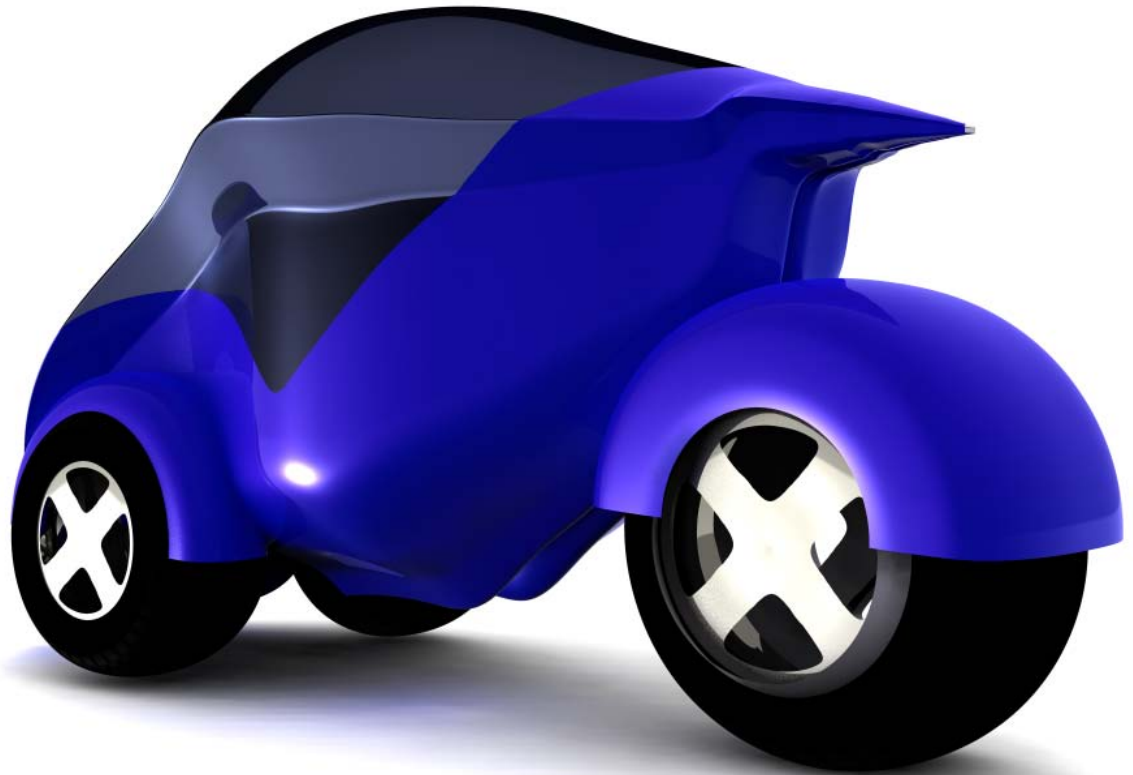

Concept Car created using ImageStudio

Design Process - Formalization

Fabrication of scaled model or prototype



Full Scale Rapid Prototype and Fabricated Model

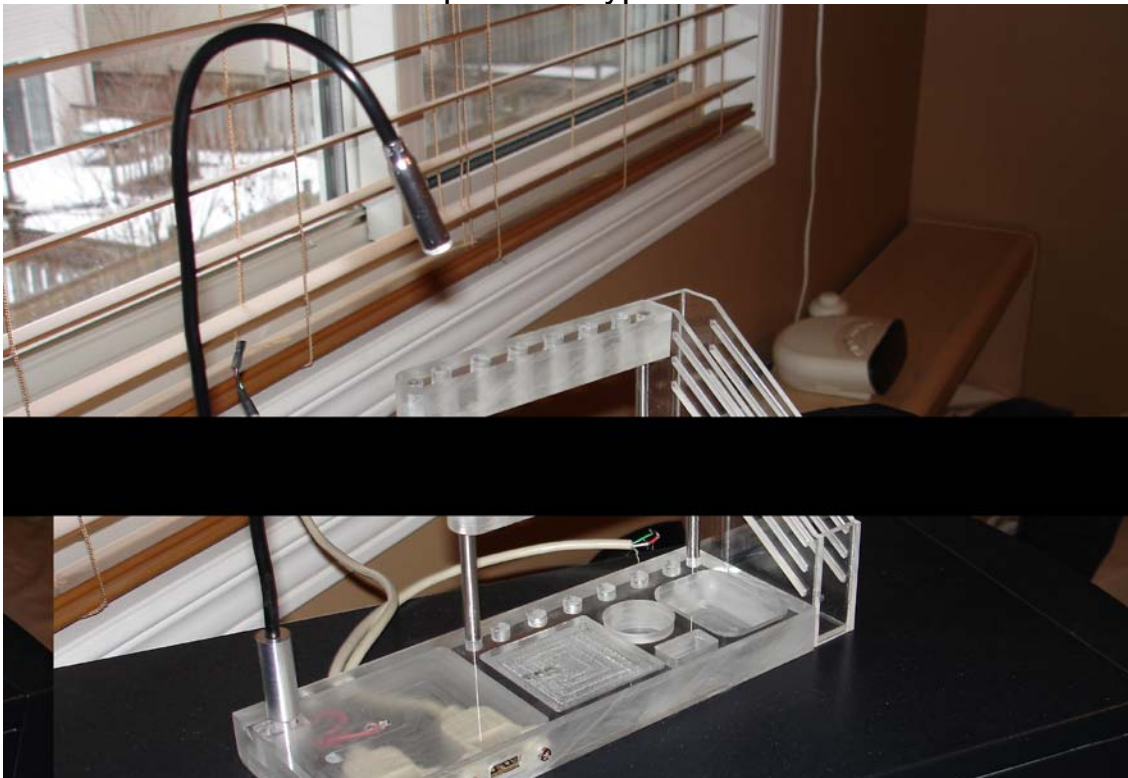

Fabricated Prototype

Sample Student Handouts

The Design Process

Creating a Design Notebook

Concept and Scaled Sketches

Concept Car Design Brief

Solar Car Final Report

The Design Process

Design is a progressive process that follows a general course of 4 stages:

- RESEARCH research and analysis of what's gone before
- CONCEPT a search for ideas which solve problems
- DEVELOPMENT a search for formal characteristics
- FORMALIZATION working drawings and models for manufacture

Thinking during the Design Process:

The stages in the design development are characterized by the following kinds of thinking:

Marketing	requires knowledge of the company, the competitors, the marketplace, the customers and the price.
Human Factors	the study of people sizes and how they relate to the design
Manufacturing	will it be mass produced and from which materials and manufacturing process
Form Giving	aesthesis

Creating a Design Notebook

Task: Create a Design Notebook to be used for the all brainstorming, note taking, calculations, and sketches.

Requirements: Your Design Notebook must contain the following sections:

- Section for preliminary sketches
- Sections for scaled sketches
- Section for calculations
- Section for note taking
- Section for Imperial/Metric conversions
- Section for Glossary of Terms -Design and Manufacturing
- Section for Formulas and Tables

The Design Notebook can be created from any type of material and can be of any size. The Design Notebooks are to be submitted at the beginning and end of term for evaluation. The sections of your notebook can be placed in any order.

Concept and Scaled Sketches

Concept Sketches

- You should have a minimum of 10 –1 5 sketches.
- They can be completed in pencil or marker (not pen).
- Colour the sketch that has been chosen for your final design.
Try to colour the sketch as the actual materials i.e. Plastics/Metals
Use markers or pencil crayons.
- Concept Sketches are not drawn to scale.
- Include any notes of functions or features not evident by the sketch.
- Concept Sketches are drawn freehand.

Scaled Sketches

All Scaled Sketches are to be completed on graph paper (supplied).

- Each scaled sketch will be drawn at 1:1 scale (full scale).
- The front, top, side and back views of the controller are required.
- Scale, set square, circle/ellipse template, French curve and compass should be used to produce a accurate and neat set of scaled sketches.
- The sketches will also include all dimensions and notes identifying all buttons and features of the controller.
- Scaled Sketches are produced in pencil only.

Concept Car Design Brief

Objective To design a concept vehicle for the physically less able to improve mobility in an urban environment and accommodate the driver and their wheelchair. The power source for the vehicle should have a minimum impact on the environment.

Inspiration Complete creative freedom on inspirational stimuli
NO EXISTING CONTEMPORARY AUTOMOTIVE DESIGNS

Design Criteria

- 3-5 doors
- Powered by alternative technologies
- 1 new technology
- Panoramic roof glass
- High Intensity Discharge (HID) Headlamps
- Light Emitting Diode (LED) Rear Tail Lamps
- Suggested Dimensions
 - 4.5 m in length
 - 1.8 m in width
 - 1.5 m in height
 - 2.7 m wheelbase

Software Used

- Autodesk SketchBook Pro
- Autodesk AliasStudio
- Autodesk Image Studio
- Autodeesk Inventor Professional
- Google Picasa

Specialized Hardware WACOM tablet and pen

Requirements

- Inspiration Collage
- Logo and name
- Concept Sketches
- Scaled Sketches
- 3D CAD Model
- Render Images
- 1/10 Scale Clay Model
- CNC Scaled Model
- Rapid Prototype Model
- Final Report

Solar Car Project Final Report

- The report is to be completed on MS word.
- The report is to be completed in proper sentences and paragraphs.
- The report will include the following information listed below:
- List and explain all the major steps required to design, produce CAD drawings and manufacture your solar car.
- Include the steps required to produce the AliasStudio and Inventor drawings. List and explain all the manufacturing process and equipment necessary to fabricate your design.
- Include images in your report to help explain the process.
- Are there aspects of your solar car that you would change or re-design?
- Explain four design considerations the effect the performance of the solar car.
- Explain the following terms: *Rolling Resistance, Gear Ratio, Aerodynamics and Wheel Base.*
- Calculate the time required for your solar car to travel 50 M.
- (Use 500 rpm as the electric motor speed)

Sample Rubrics

Design Notebook

Dimensioning a Technical Drawing

Concept and Scaled Sketches

Solar Car Design and Final Assembly

Design Notebook

Criteria	Level 1	Level 2	Level 3	Level 4
Knowledge/ Understanding	demonstrates limited understanding of concepts such as organization and continuity of information	demonstrates some understanding of concepts such as organization and continuity of information	demonstrates considerable understanding of concepts such as organization and continuity of information	demonstrates thorough and insightful understanding of concepts such as organization and continuity of information
Thinking/ Inquiry	uses thinking/inquiry skills with limited effectiveness in the use of additional research tools/materials	uses thinking/inquiry skills with moderate effectiveness in the use of additional research tools/materials	uses thinking/inquiry skills with considerable effectiveness in the use of additional research tools/materials	uses thinking/inquiry skills with a high degree of effectiveness in the use of additional research tools/materials
Communication	communicates ideas / information using logical, organized and written instruction with limited clarity and accuracy	communicates ideas / information using logical, organized and written instruction with moderate clarity and accuracy	communicates ideas / information using logical, organized and written instruction with considerable clarity and accuracy	communicates ideas / information using logical, organized and written instruction with a high degree of clarity and accuracy
Application	Used media resources with limited success. The notebook was constructed /laid out poorly and had some errors.	Used media resources with moderate success. The notebook was constructed /laid out satisfactorily and had few errors.	Used media resources with considerable success. The notebook was constructed /laid out nicely and had very few errors.	Used media resources with a high degree of success. The notebook was constructed /laid out exceptionally well and had very few errors.

Dimensioning a Technical Drawing

Criteria	Level 1	Level 2	Level 3	Level 4
Knowledge/Understanding Drawing Standards	-demonstrates limited understanding of drawing standards	-demonstrates some understanding of drawing standards	-demonstrates considerable understanding of drawing standards	-demonstrates high degree of understanding of drawing standards
Knowledge/Understanding Dimensioning Rules	-demonstrates limited understanding of dimensioning rules	-demonstrates some understanding of dimensioning rules	-demonstrates considerable understanding of dimensioning rules	-demonstrates high degree of understanding of dimensioning rules
Thinking/Inquiry Location of Dimensions	-using thinking/inquiry skills with limited effectiveness	- using thinking/inquiry skills with some effectiveness	- using thinking/inquiry skills with considerable effectiveness	- using thinking/inquiry skills with a high degree of effectiveness
Communication Dimensioning	-communicates dimensions with limited clarity	- communicates dimensions with some clarity	- communicates dimensions with considerable clarity	-communicates dimensions with a high degree of clarity
Application Using Inventor	-demonstrated limited level of ability using Inventor	- demonstrated some level of ability using Inventor	- demonstrated considerable level of ability using Inventor	- demonstrated a high degree of ability using Inventor

Concept and Scaled Sketches

Criteria	Level 1	Level 2	Level 3	Level 4
Knowledge/ Understanding Design criteria	-demonstrates limited understanding of design criteria	demonstrates some understanding of design criteria	demonstrates considerable understanding of design criteria	demonstrates high degree of understanding design criteria
Thinking/Inquiry Creativity and originality	using thinking/inquiry skills with limited effectiveness	using thinking/inquiry skills with some effectiveness	using thinking/inquiry skills with considerable effectiveness	using thinking/inquiry skills with a high degree of effectiveness
Communication Dimensioning	communicates dimensions with limited clarity	communicates dimensions with some clarity	communicates dimensions with considerable clarity	communicates dimensions with a high degree of clarity
Application Neatness	demonstrated limited level of neatness with sketches	demonstrated some level of neatness with sketches	demonstrated considerable level of neatness with sketches	demonstrated a high degree level of neatness with sketches
Application Level of detail	demonstrated limited level of detail with sketches	demonstrated some level of detail with sketches	demonstrated considerable level of detail with sketches	demonstrated a high degree of detail with sketches

Solar Car Design and Final Assembly

Criteria	Level 1	Level 2	Level 3	Level 4
Knowledge/Understanding Design criteria	-demonstrates limited understanding of design criteria	-demonstrates some understanding of design criteria	-demonstrates considerable understanding of design criteria	-demonstrates high degree of understanding of design criteria
Knowledge/Understanding Integrity to Design	-demonstrates limited integrity to design	-demonstrates some integrity to design	-demonstrates considerable integrity to design	-demonstrates high degree of integrity to design
Thinking/Inquiry Creativity and originality	-using thinking/inquiry skills with limited effectiveness	- using thinking/inquiry skills with some effectiveness	- using thinking/inquiry skills with considerable effectiveness	- using thinking/inquiry skills with a high degree of effectiveness
Thinking/Inquiry Design considerations	-using thinking/inquiry skills with limited effectiveness	- using thinking/inquiry skills with some effectiveness	- using thinking/inquiry skills with considerable effectiveness	- using thinking/inquiry skills with a high degree of effectiveness
Application Final assembly	-demonstrated limited level of ability assembling the solar car	- demonstrated some level of ability assembling the solar car	- demonstrated considerable level of ability assembling the solar car	- demonstrated a high degree of ability assembling the solar car